

Hygienic Processing



bürkert
FLUID CONTROL SYSTEMS

Content

- 5 _____ Company Profile
- 6 _____ Products and Systems
- 9 _____ Hygienic Processing
- 13 _____ Utilities: Steam and Heat Transfer
- 14 _____ Utilities: Clean-in-Place (CIP)
- 17 _____ Utilities: Water Treatment
- 20 _____ Process: Fermentation
- 23 _____ Process: Downstream Processing
- 24 _____ Process: Batching and Mixing
- 27 _____ Process: Filling Control
- 30 _____ Contacts



Hygienic Processing.

Hygienic Processing is a customer-oriented concept to combine the physical attributes of the application environments from your world. In this overview you will find a virtual factory to examine some of our core process competences. We believe we have intimate knowledge and significant insight into the application environments, which traverse a spectrum of processing industries from pharmaceutical, nutraceutical, cosmetic, brewery, beverage, dairy, juice production, confectionary, and petfood.

We intend to collaborate with you in the real physics of batching, cleaning and sterilizing, water producing and distributing, filling, heating, cooling, separating, fermenting, distilling, or evaporating, where we can share our experience in complete control loops for flow, conductivity, pH, temperature, pressure, and level. We can help you determine the most effective communications architecture to help you really see what is happening in your plant from the control room or the board room.

Everyone in our organization is interested in listening to you with the aim of presenting only the most appropriate solution fluently in your daily application language. The inherent expertise available within the Bürkert organization exists to make your life simpler. Our versatile systems highlight our continuous customer-oriented innovation and are developed to simplify the hygienic world to save you time.

An otherwise unattainable synergy of hardworking valve elements, process actuation, sensors, and networked communication provides a true single source of remarkable attractive systems, peace of mind, process safety, and joy of use.

In the world of hygiene where compactness, smart communication, plant footprint, wash-down, dead legs, cross-contamination, and validation are everyday concerns, we provide process efficiency and higher yields by offering you unlimited process modularity.

Welcome to the Fascinating World of Fluid Control Systems.

Measurement and control: When it comes to working with fluids and gases, we are at your side—as a manufacturer of sophisticated products, as a problem-solver with an eye for the big picture, and as a partner offering you reliable advice. Ever since we started in 1946, we have developed into one of the world's leading suppliers of Fluid Control Systems. But at the same time we have kept our status as a family-run business with a foundation of strong basic values to highlight the way we think and act.

What we build on: Experience

We bring together over 60 years of applied knowledge, theoretical expertise and all-round experience in the field of Fluid Control Systems. We at Bürkert have always taken care to ensure that the insights gained in working on innumerable products and projects are passed on, not only among our over 1,800 employees in various locations and divisions but also from one Bürkert generation to the next. We focus all our curiosity, passion and commitment on one goal: to provide solutions that take your company that essential step forward.

What sets us apart: Closeness

To engineer expert solutions with added value, you need to be close to your customers and their problems—as we are. For us at Bürkert, closeness means personal closeness: We listen to your every word and do everything in our power to devise and implement the best solution for your needs. But closeness also applies in a technical sense: We know exactly what role our products play in your complex processes. And last but not least, we understand closeness in a geographical sense: Our global presence with over 35 branches and seven production sites allows our customers to draw on technological innovations from all over the world.

What drives us forward: Courage

We aim to surpass your expectations. To make it happen, one quality is vital: courage. The courage not just to look forward but to move forward, to challenge conventional wisdom, to do things differently, to tackle problems others think are impossible, to never give up when the going gets tough. We demonstrate this courage time and again. Our wealth of experience is the solid platform on which our courage is based. It allows us to turn courage into creativity, convert off-beat ideas into surprising innovations and put together individual components to create completely new systems that open up unexpected possibilities.

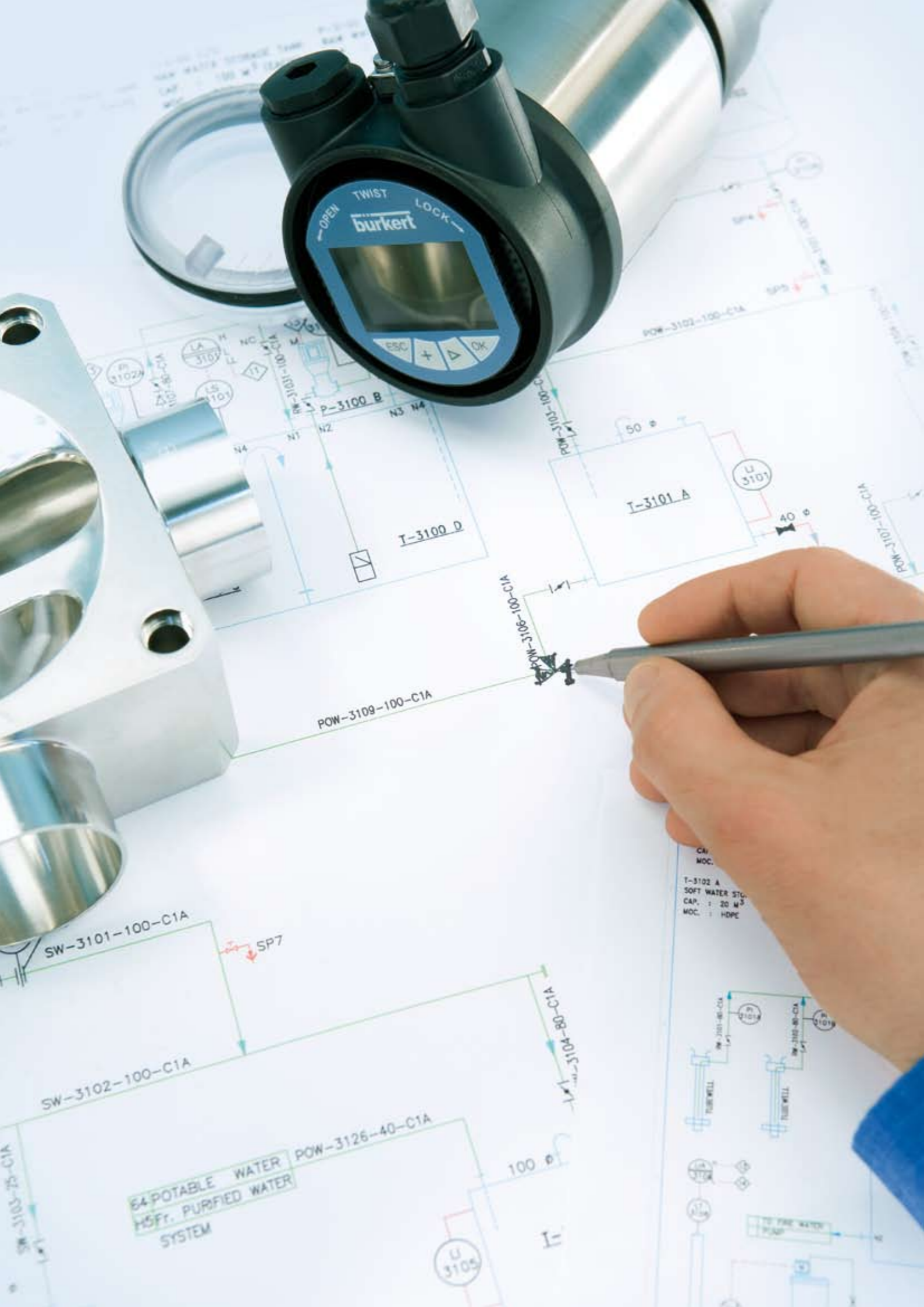



Good from Every Angle: Our Products.

You can see Bürkert as a supplier who simply provides you with good products. We are happy to fill that role—but what really makes us proud is when you see us as a partner who joins you in getting the job done—however complex. Even if the problem seems irresolvable, challenge us, put our courage to the test—it is the tough challenges that drive us, moving you and us forward.

We are at your side at all times with a seamless range of services, from consulting and engineering through installation, testing, and after-sales service. No matter if it is an individual component or a groundbreaking new system for the entire process of measurement and control.

We work with engineering consultants, integrators, contractors, original equipment manufacturers, and end users in a spectrum of industries from pet food to dairy to biotech. Expertise in CIP, WFI, batching and mixing, filling, distillation, bioreactors, steam and heat transfer, chromatography, and filtration ... in your application language. Speaking a common language eases communication and lays the foundation for your success.

Innovative, Value-added Solutions Combine the Best of All Worlds.

Fluids are fascinating media. And it is this very fascination with liquids and gases that drives us to develop ever-new devices that can handle them even better. We are one of the few suppliers on the market to cover the complete control loop. Our current product range extends from solenoid valves through process and analytical valves to pneumatic actuators and sensors.

To meet our customers' ever-increasing demands, the people at our four research and development centers constantly work on improving both our individual products and our range as a whole. Products that solve a particular problem perfectly, that offer a true value-added benefit over other products, and that meet specific industry requirements.

In the hygienic processing arena, we have worked continuously to be involved in the latest specifications, requirements, and special interest groups which push the industry towards higher standards and improved value for their customers. We believe we have done the work which allows you to have peace of mind. When you specify Bürkert you know you will receive real, traceable, consistent quality ... quickly.

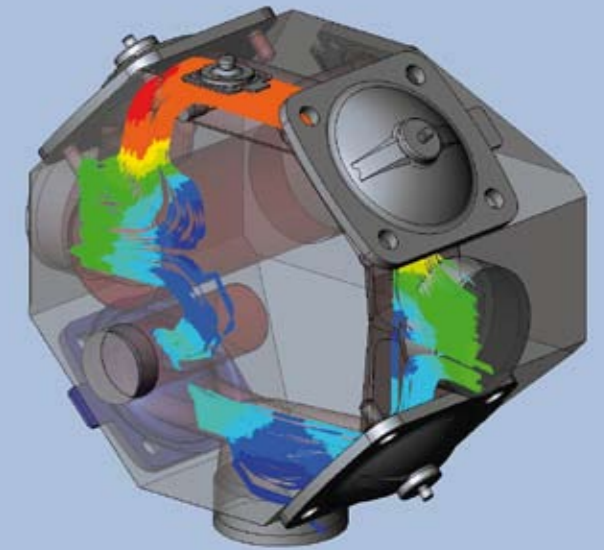
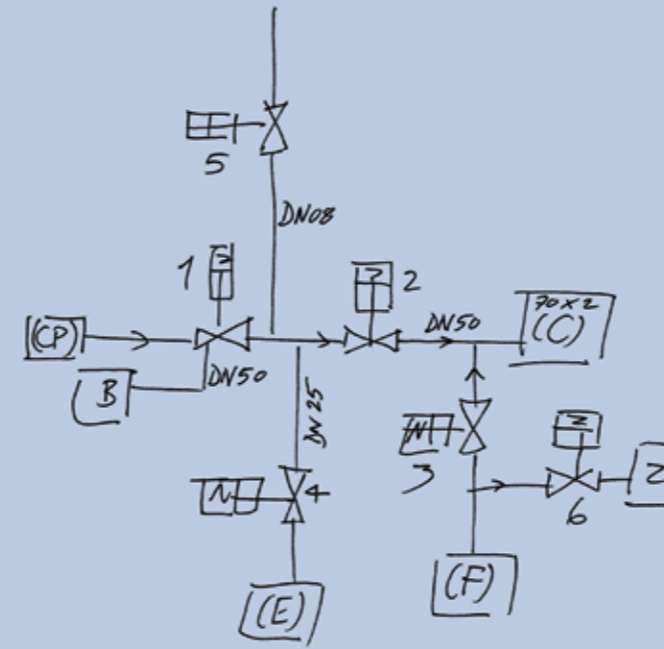

IDEAS & CONSULTING

SIMULATION & DEVELOPMENT

SYSTEM DEVELOPMENT

PROTOTYPE

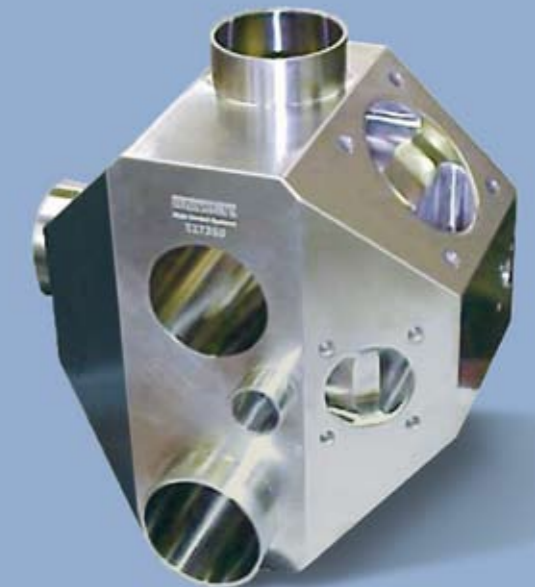

We Help Your Ideas Flow.

In hygienic processing industries, measuring and controlling the flow of liquids and gases demands superior instrument performance and networkability.

Standard connectivity with modular, decentralized monitoring, intelligence, and diagnostics are the platform for flow control networks which provide reliable productivity data from your plant level flow network.

Fluids like ultra-pure water through to those with extreme viscosities, high solid concentrations and low conductivity, and clean or sterile manufacturing application environments present a wide range of flow challenges that we understand.

Components are designed according to global norms and standards for your critical food, cosmetic, beverage, or drug manufacturing processes.

Proven reliability, superior accuracy, and virtually maintenance-free service ensure Bürkert's systems deliver unsurpassed total performance in the form of complete flow control loop systems.

Deploy control when and where you want it. We fit your control strategy.



8644 process control center



1066 control top for remote control and feedback of process valves



8644 AirLINE process control center



EXPERIENCE

There are things which are not inherently yours. You have to gather them bit by bit, you receive them from others, and you constantly have to acquire them anew. That is what makes them so valuable. Experience is one of those things. For instance, because of our many years of experience with hygienic processes and workflows, we can provide our extensive services to you—from consulting, development, and installation to testing and after-sales service. Whether individual product solutions or a pioneering new system for the entire measurement and control process: Benefit from our experience!



Hot Ideas for Precise Control.

Bürkert provides cutting-edge solutions for heat transfer applications in your world.

From pasteurizer control to simple tempering of water, autoclaving of canned food to sterilization of dental equipment, our experience is steam. Your use of steam as a heat transfer media, a cleaning agent, or as a crucial sterile ingredient can be regulated precisely with Bürkert systems and solutions.

Through constant innovation our technology is designed to work with your steam in your hygienic environment.

Experience and knowledge acquired over many years means our systems are deployed globally. Our local engineering teams can take your process layout ideas and help you turn them into reality.

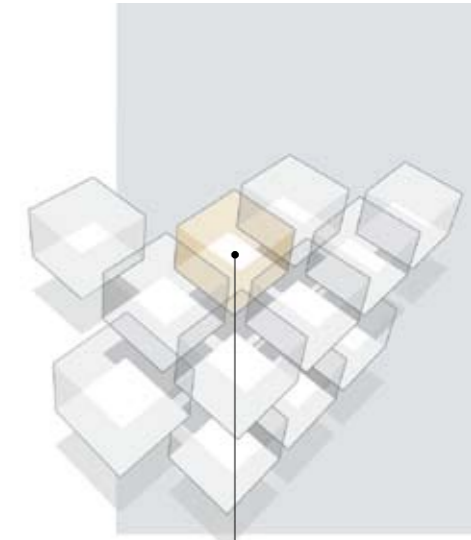

Steam is an essential ingredient.

Hardworking valves are just the beginning.



On-off and continuous steam valves



8400 temperature transmitter



1067 valve-mounted PID process controller

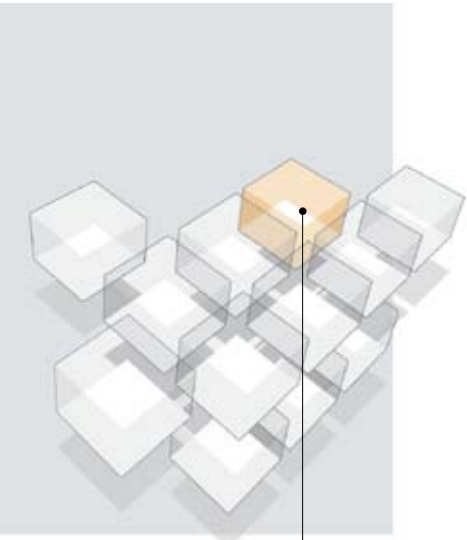

CIP and SIP keep your customers safe.

Safe in Bürkert's Hands.

Your customers place trust in your product and safety is related to your brand.

Each stage of your CIP/SIP regime can be controlled and safely documented. Our stable and rugged components are designed for the harsh shifts from acid to base, and for the demands of washdown.

Our components and system solutions bring peace of mind. Your pH, conductivity, pressure and flow are all important to your consumers.

Reliability in switching from water to clean steam and from chemical to surfactant is standard in a range of valves which are designed for this purpose.

All of the CIP parameters are safe in Bürkert's hands allowing you to make your product with confidence.

From make-up loop control to design of cleanable components, we are with you.



8226 inductive conductivity transmitter for CIP systems



3237 sanitary divert valve



8644 AirLINE process control center





Water—Your Most Valuable Ingredient.

In many industries water is known as the most important ingredient. Water quality is therefore often essential to the success of the product. Whether it affects the taste of beer or the sterility of an injectable saline solution, traceability and certification of water quality is standard procedure. We take the risk out of water production, distribution, and use.

Bürkert is involved in the complete water supply chain from ground-water treatment and incoming water supply processing to your most stringent requirements, inline verification, and final decontamination, treatment, and/or neutralization.

In the production of de-mineralized water, purified water, and water for injection(s) Bürkert's technology and expertise are employed with confidence.

Our experience in water is evident: pH, conductivity, flow, pressure and level are under control.

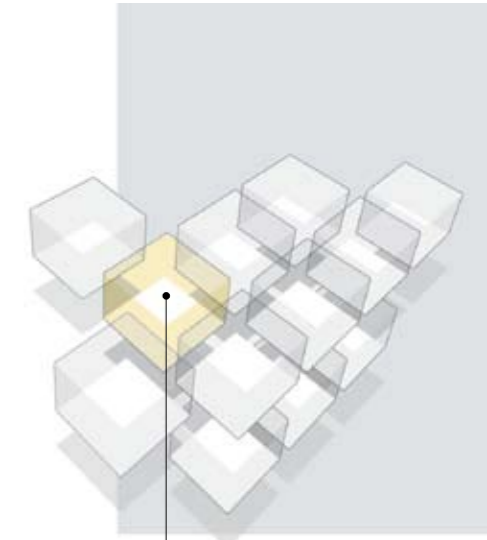

Clean water is central to life and to your factory.



2030 chemical and water valves



Multi-channel controller for water treatment systems



8025 flow transmitter



COURAGE

Those who only work toward optimizing things that already exist will eventually reach the limits—technically, financially, or personally. In order to overcome these limits, courage is needed: The courage to be different and trust one's own ideas; the courage to venture into the unknown, searching for new ways to develop products that have never existed before. We have this courage. By pooling and utilizing our competencies across all sectors, you benefit from our cumulative knowledge of hygienic processes—whether it is in pharmaceuticals, the food industry, or the cosmetic industry.

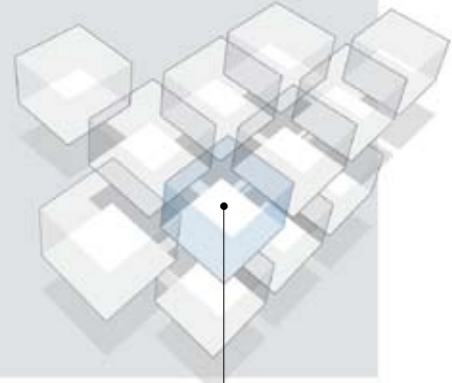

Fermentation is the beginning of many products.

A Culture of Decentralized Networked Control.

Since prehistoric times humans have been taking control of the fermentation process. From Pasteur to Buchner to the Carlsberg scientists, the conversion of juice into wine, grains into beer, milk to yogurt, carbohydrates into carbon dioxide to raise bread, and sugars in vegetables into preservative organic acids. Today, fermentation provides a diversity of flavors, aromas, and textures in food substrates. It preserves, enriches, and detoxifies and produces important nutrients and drugs.

We have many years of experience in this area and our knowledge of the process provides our clients with confidence. Process safety is evident in our components for fermentor gas control, pH and pressure monitoring, and modular fieldbus solutions which are used to join individual reactors into coordinated processes.

Fermenting requires control of both liquids and gases, temperature and pressure.



8645 FreeLINE control center for challenging environments



Mass flow controllers and meters for fermentor gas control



Diaphragm valve mounted with PID process controller





Downstream Processing.

From filtration of beer to separation and identification of active drug ingredients, our unlimited modularity saves you valuable plant space and offers you peace of mind from dead legs and cross-contamination. Less welding means less validation, and our patented designs provide faster crossover times, higher process efficiencies, and higher yields.

Our unique Robolux multiway/multiport valves are compact and smart and our instrumentation for pressure, level, conductivity, and pH is easy to commission. Communication inside the skid may be made with AS-Interface and between skids with your preferred fieldbus.

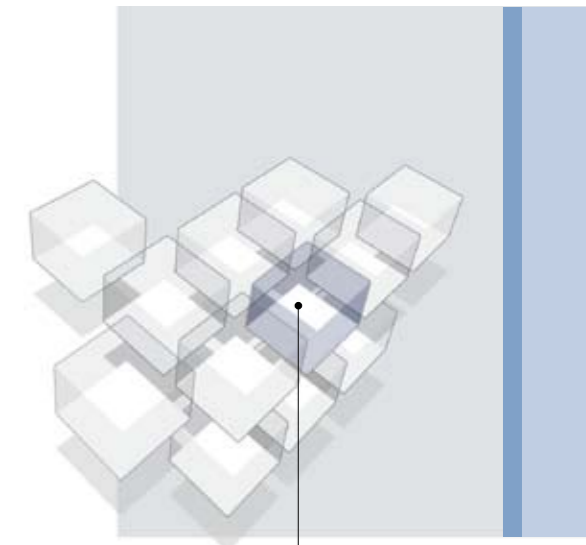

Filtration, separation and chromatography make up downstream processing.

Preparation for separation requires precise and flexible systems.



Multiport solutions for chromatography and filtration equipment



pH and conductivity sensors and transmitters for hygienic processes



8650 AirLINE Ex process control center for solvent areas

Recipe for Success.

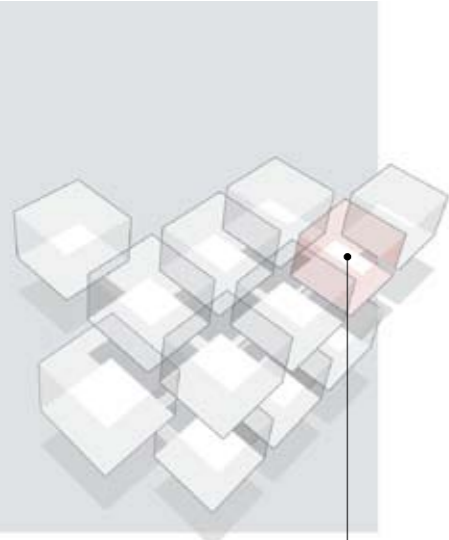

The ability to mix and batch lets your customers enjoy your products.

Precision, reliability, repeatability, and flexibility are the cornerstones of batching and mixing.

From simple components to dose chemicals and specific valves for yogurt filling to fully tested and approved systems for bread ingredients or pasta sauce.

We have batched and mixed primary active drug ingredients worth thousands of euros per gram, cookie mix, shampoo fragrances, cocoa butter ingredients, liquid flour, and syrups with whole fruit pieces.

Only the right ingredients count for the right taste and texture. Bürkert systems have brought peace of mind to thousands of customers by ensuring just the right mix.

The right components plus the right experience makes systems future integrated.



8035 versatile and simple to use batch controller



8311 pressure transmitter



8644 AirLINE process control center





Refreshing Solutions.

Your production lines rely on the speed of your filling lines. Whether you fill 200 barrels per day or 20,000 packs per hour, our unique solutions help you exceed your targets.

Whether you are filling portion packages, cartons, briks, bags, or kegs, we are part of the solution for long, high volume production runs at lower operating costs. We help you to reach higher productivity and greater space efficiency in high-speed filling machines and we solve sticky problems at the plant level. Our products have proven themselves with superior cycle life, sterility, accuracy, and repeatability in plants around the world. Our support and experience is ready and willing. Whether your goal is cost-driven innovation for a new machine, getting the whole fruit into a yogurt container, or boosting production on your filling floor we are here to help.

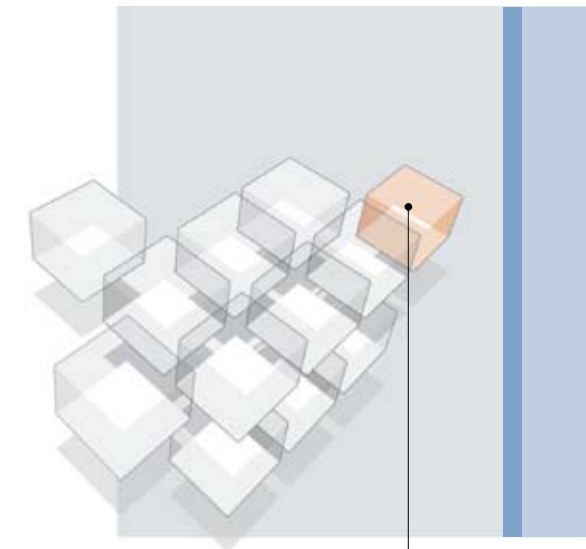

Bürkert offers many standard and customized solutions for filling.

Filling industries demand reliable, fast, and accurate solutions.



8055 high frequency mass flow batch controller



Range of standard and custom valves for accurate and reliable filling



8644 AirLINE process control center



CLOSENESS

There are things we simply take for granted. Only when they are gone, do we realize how important these things really were. This applies in particular to closeness. Without closeness, it is very difficult to build relationships and a good understanding of one another. As an established medium-sized company, we know that. And that is why we are always there for you. Working with you, we develop the best possible solutions for your projects in the area of hygienic processes. Our global presence in 35 locations enables us to press ahead with technical innovations for our customers around the world.

Contacts at Bürkert

North and South America

Brazil

Bürkert-Contromatic Brasil Ltda.
Rua Américo Brasiliense,
2171 cj.306 a 310
Chacara Santo Antônio
04715-005 São Paulo - SP
BRAZIL
Tel: +55 (0)11-5182 0011
Fax: +55 (0)11-5182 8899
E-mail: burkert@burkert.com.br

Canada

Bürkert Contromatic Inc.
5002 South Service Road
Burlington, Ontario L7L 5Y7
Canada
Tel: +1 905-632 30 33
Fax: +1 905-632 38 33
E-mail: sales.ca@burkert.com

USA

BURKERT CONTROMATIC CORP.
2602 McGaw Avenue
Irvine, CA 92614
USA
Tel: +1 949-223 31 00
Fax: +1 949-223 31 98
E-mail: marketing-usa@burkert.com

Europe

Austria

Bürkert-Contromatic G.m.b.H.
Diefenbachgasse 1-3
AT-1150 Wien
Tel: +43 (0)1-894 13 33
Fax: +43 (0)1-894 13 00
E-mail: info@burkert.at

Belgium

Bürkert Contromatic NV
Bijkhoevelaan 3
BE-2110 Wijnegem
Tel: +32 (0)3-325 89 00
Fax: +32 (0)3-325 61 61
E-mail: sales.be@burkert.com

Czech Rep.

Bürkert-Contromatic G.m.b.H. organizacni slozka
Krenova 35
CZ-602 00 Brno
Tel: +420 543-25 25 05
Fax: +420 543-25 25 06
E-mail: obchod@burkert.cz

Denmark

Bürkert-Contromatic A/S
Hørkær 24
DK-2730 Herlev
Tel: +45 44-50 75 00
Fax: +45 44-50 75 75
E-mail: info.dk@burkert.com

Estonia

Bürkert Oy Eesti
Laki 11 E
EE-12915 Tallinn
Tel: +372 6440 698
Fax: +372 6313 759
E-mail: info@burkert.ee

Finland

Bürkert Oy
Atomitie 5
FI-00370 Helsinki
Tel: +358 (0)207 412 550
Fax: +358 (0)207 412 555
E-mail: sales.fi@burkert.com

France

BURKERT CONTROMATIC SAS
Rue du Giessen
FR-67220 Triembach au Val
Tel: +33 (0)388-58 91 11
Fax: +33 (0)388-57 20 08
E-mail: burkert.france@burkert.com

Germany

Bürkert GmbH & Co. KG
Christian-Bürkert-Straße 13 - 17
DE-74653 Ingelfingen
Tel: +49 (0)7940-10-111
Fax: +49 (0)7940-10-448
E-mail: info@de.buerkert.com

Italy

Bürkert Contromatic Italiana S.p.A.
Centro Direzionale „Colombirolo“
Via Roma, 74
IT-20060 Cassina De' Pecchi (Mi)
Tel: +39 02-959 071
Fax: +39 02-959 07 251
E-mail: info@burkert.it

Norway

Bürkert-Contromatic A/S
Hvamstubben 17
NO-2013 Skjetten
Tel: +47 63-84 44 10
Fax: +47 63-84 44 55
E-mail: buerkert@online.no

Netherlands

Bürkert Contromatic BV
Computerweg 9
NL-3542 DP Utrecht
Tel: +31 (0)346-58 10 10
Fax: +31 (0)346-56 37 17
E-mail: info@burkert.nl

Portugal

Tel: +351 212 898 275
Fax: +351 212 898 276
E-mail: portugal@burkert.com

Poland

Burkert-Contromatic GmbH Oddzial w Polsce
Bernardynska street 14 a
PL-02-904 Warszawa
Tel: +48 (0)22-840 60 10
Fax: +48 (0)22-840 60 11
E-mail: buerkert@buerkert.pl

Spain

Bürkert Contromatic S.A.
Avda. Barcelona, 40
ES-08970 Sant Joan Despi, Barcelona
Tel: +34 93-477 79 80
Fax: +34 93-477 79 81
E-mail: spain@burkert.com

Sweden

Bürkert-Contromatic AB
Skeppsbron 13 B
SE-211 20 Malmö
Tel: +46 (0)40-664 51 00
Fax: +46 (0)40-664 51 01
E-mail: info.se@burkert.com

Switzerland

Bürkert-Contromatic AG Schweiz
Bösch 71
CH-6331 Hünenberg ZG
Tel: +41 (0)41-785 66 66
Fax: +41 (0)41-785 66 33
E-mail: info.ch@burkert.com

Turkey

Burkert Contromatic Akiskan Kontrol Sistemleri Ticaret A.S.
1203/8 Sok. No2-E
TR-Yenisehir, Izmir
Tel: +90 (0)232-459 53 95
Fax: +90 (0)232-459 76 94
E-mail: burkert@superonline.com

United Kingdom

Burkert Contromatic Limited
Brimmscombe Port Business Park
Brimmscombe, Stroud
Glos, GL5 2QQ / UNITED KINGDOM
Tel: +44 (0)1453-73 13 53
Fax: +44 (0)1453-73 13 43
E-mail: sales.uk@burkert.com

Africa

South Africa

Bürkert Contromatic (Proprietary) Limited
233 Albert Amon Road
Millennium Business Park
Meadowdale,
Germiston
SOUTH AFRICA
Tel: +27 (0)11-574 60 00
Fax: +27 (0)11-454 14 77
E-mail: sales.za@burkert.com

Asia Pacific

Australia

BURKERT CONTROMATIC AUSTRALIA PTY. LIMITED
15 Columbia Way, Norwest Business Park
Baulkham Hills, NSW 2153, Australia
Tel: +61 2 8853 6353
Fax: +61 2 8853 6363
E-mail: sales.au@burkert.com

Brisbane

BURKERT CONTROMATIC AUSTRALIA PTY. LIMITED
Unit 4/43 Sandgate Road
Albion Queensland 4010
Tel: +61 733 269 640
Fax: +61 733 269 621

Melbourne

BURKERT CONTROMATIC AUSTRALIA PTY. LIMITED
Unit 11/26-30 Howleys Road
Notting Hill Victoria 3168
Tel: +61 385 459 700
Fax: +61 395 626 599

Perth

BURKERT CONTROMATIC AUSTRALIA PTY. LIMITED
104 Westpoint, 396 Scarborough Beach Road
Osborne Park Western Australia 6017
Tel: +61 894 443 980
Fax: +61 892 434 022

China

Burkert Contromatic (Shanghai), Co., Ltd.
Room J1, 3rd floor
207 Tai Gu Road
Wai Gao Qiao Free Trade Zone
Shanghai 200131, P.R. China
Tel: +86 21-5868 21 19
Fax: +86 21-5868 21 20
E-mail: info.chn@burkert.com

Beijing

Burkert Contromatic (Shanghai), Co., Ltd.
Room A 1708, Luowa Building, No.203
Er Qu Lizezhongyuan, Wangjing,
Chaoyang District
Beijing P.R. China, 100102
Tel: +86 10 64399783, 64399793
Fax: +86 10 64399612

Chengdu

Burkert Contromatic (Shanghai), Co., Ltd.
Room 603-604, Fuji Building
26 Dongfeng Road, Shudu Dadao
Chengdu P.R. China, 610061
Tel: +86 28 8443 9064
Fax: +86 28 8445 1341

Guangzhou

Burkert Contromatic (Shanghai), Co., Ltd.
Room 1502, Tower 4, Dong Jun Plaza
828 - 836 Dong Feng Road East
Guangzhou P.R. China, 510080
Tel: +86 20 8769 8379, 8767 8703
Fax: +86 20 87671131

Shanghai

Burkert Contromatic (Shanghai), Co., Ltd.
Room 501/502 Xin Gai Nian Mansion
No.39 Wu Zhong Road
Shanghai P.R. China, 200233
Tel: +86 21 6486 5110
Fax: +86 21 6487 4815

Suzhou

Burkert Contromatic (Suzhou), Co., Ltd.
Unit A5, Suhong Square
No.81 Suhong West Road
SIP Suzhou P.R. China, 215021
Tel: +86 512 6265 9881
Fax: +86 512 6265 9882

Hong Kong

Burkert Contromatic (China/HK) Limited
Unit K, 9/Floor, Kwai Shun Industrial Centre
No. 51-63 Container Port Road
Kwai Chung, N.T., HONG KONG
Tel: +852 248 012 02
Fax: +852 241 819 45
E-mail: info.hkg@burkert.com

India

Burkert Contromatic PVT Ltd
Apex Towers, 1st Floor, No. 54 II Main Rd
RA Puram
Chennai 600 028, India
Tel: +91 (0)44-4230 3456
Fax: +91 (0)44-4230 3232
E-mail: sales.in@burkert.com

Japan

Burkert Ltd.
Imasu moto asakusa-building
4-9-14 Moto Asakusa, Taito-ku
Tokyo 111-0041, Japan
Tel: +81 (0)3-5827-0066
Fax: +81 (0)3-5827-0067
E-mail: info.jpn@burkert.com

Osaka

Burkert Ltd.
2-8-8-1103 Higashi Nakajima, Yodogawa-ku
Osaka 533-0033, JAPAN
Tel: +81 (0)6-6320-0880
Fax: +81 (0)6-6320-0881

Korea

Burkert Contromatic Korea Co., Ltd.
C-401, Micro Office Bldg. 554-2
Gasan-Dong, Keumcheon-Gu
Seoul 153-803, Korea
Tel: +82 (0)2-3462 5592
Fax: +82 (0)2-3462 5594
E-mail: info.kor@burkert.com

Malaysia

BURKERT CONTROMATIC SINGAPORE PTE LTD
2F-1, Tingkat Kenari 6
Sungai Ara
11960 Penang, Malaysia
Tel: +60 (0)4-643 5008
Fax: +60 (0)4-643 7010
E-mail: info.sin@burkert.com

New Zealand

BURKERT CONTROMATIC NEW ZEALAND LIMITED
44 Rennie Drive
Airport Oaks, Auckland 2022
New Zealand
Tel: +64 (0)9-256 77 37
Fax: +64 (0)9-256 77 47
E-mail: sales.nz@burkert.com

Philippines

BURKERT CONTROMATIC PHILIPPINES, INC.
Nassons Mercantile Building
8467, West Service Road Km 14
South Superhighway, Sunvalley
1700 Paranaque City, Philipines
Tel: +63 (0)2-776 43 84
Fax: +63 (0)2-776 43 82
E-mail: info.rp@burkert.com

Singapore

BURKERT CONTROMATIC SINGAPORE PTE LTD
51 Ubi Avenue 1, #03-14
Paya Ubi Industrial Park
Singapore 408933, Singapore
Tel: +65 6844 2233
Fax: +65 6844 3532
E-mail: info.sin@burkert.com

Taiwan

Burkert Contromatic Taiwan Ltd.
9 F, No. 32, Chenggong Road, Sec. 1,
Nangang District
TAIPEI
Taiwan 115, R.O.C.
Tel: +886 (0)2-2653 7868
Fax: +886 (0)2-2653 7968
E-mail: info.rc@burkert.com

Credits:

© Christian Bürkert GmbH & Co. KG
Concept and realization:
wolf media lounge, Berlin
Photography: Studio Flamisch, Düsseldorf;
Münch & Schmidt, Stuttgart;
All people shown in the brochure are
employees at Bürkert.
Thank you very much for your support
(and spirit).

Bürkert Fluid Control Systems

Christian-Bürkert-Straße 13-17
74653 Ingelfingen
Germany

Tel. +49 (0) 7940/10-0
Fax +49 (0) 7940/10-204

info@burkert.com
www.burkert.com